

# Fluvial landscape ecology: addressing uniqueness within the river discontinuum

GEOFFREY C. POOLE

*Eco-metrics, Inc., Tucker, GA, U.S.A. and Institute of Ecology, University of Georgia, Athens, GA, U.S.A.*

## SUMMARY

1. As rivers and streams are patchy and strongly hierarchical systems, a hierarchical patch dynamics perspective can be used as a framework for visualising interactions between structure and function in fluvial landscapes. The perspective is useful for addressing fundamental attributes of lotic ecosystems, such as heterogeneity, hierarchy, directionality and process feedback occurring across spatial scales and for illustrating spatio-temporal linkages between disparate concepts in lotic system ecology such as the River Continuum Concept, the Serial Discontinuity Concept, the Flood Pulse Concept and the Hyporheic Corridor Concept.
2. At coarse spatial scales, the hierarchical patch dynamics perspective describes each river network as a unique, patchy discontinuum from headwaters to mouth. The discontinuum is comprised of a longitudinal series of alternating stream segments with different geomorphological structures. Each confluence in the stream network further punctuates the discontinuum because the sudden change in stream characteristics can create a 'gap' in the expected pattern of downstream transitions. The discontinuum view recognises general trends in habitat characteristics along the longitudinal profile, but creates a framework for studying and understanding the ecological importance of each stream's individual pattern of habitat transitions along longitudinal, lateral or vertical vectors at any scale.
3. Object-oriented modelling and programming techniques provide a means for developing robust, quantitative simulation models that describe the dynamic structure of patch hierarchies. Such models can simulate how the structure and function of lotic ecosystems are influenced by the landscape context of the system (the ecological conditions within which the system is set) and the metastructure (structural characteristics and juxtaposition) of finer-scale patches comprising the system.
4. A simple object-oriented, multiscale, discontinuum model of solute transformation and biological response along a stream channel illustrates how changing the branching pattern of a stream and the arrangement of its component patches along the downstream profile will result in substantial changes in predicted patterns of solute concentration and biotic community structure.
5. The importance of context, structure, and metastructure in determining lotic ecosystem function serves to underscore Hynes' (1975) concept that 'every stream is likely to be individual.' Advancing the discipline of fluvial landscape ecology provides an excellent opportunity to develop general concepts and tools that address the individual character of each stream network and integrate the concept of 'uniqueness within the river discontinuum' into our ecological understanding of rivers and streams.

*Keywords:* aquatic ecology, context, hierarchical patch dynamics, metastructure, object-oriented modelling

[I]n every respect the valley rules the stream. Its rock dominates the availability of ions, its soil, its clay, even its slope. The soil and the climate determine the vegetation, and the vegetation rules the supply of organic matter. The particulate nitrate and phosphate control the decay of the litter, and hence lie right at the root of the food cycle ... These relationships ... make it clear that every stream is likely to be individual and thus not really very easily classifiable.' Hynes (1975)

## Introduction

More than a decade ago, Pringle *et al.* (1988) and Townsend (1989) described how the concept of patch dynamics from the field of landscape ecology might be adapted to address basic questions in lotic system ecology. About 5 years later, Malanson (1993) published a text linking lotic system ecology with principles derived from landscape ecology, and recently Johnson & Gage (1997) provided a review of landscape ecology tools and techniques and their applicability to lentic and lotic systems. At the same time, the vocabulary and techniques of landscape ecology have permeated the literature on lotic system ecology (e.g. Hunsaker & Levine, 1995; Allan, Erickson & Fay, 1997; Johnson & Gage, 1997; Tabacchi *et al.*, 1998). The integration of landscape and lotic system ecology is complete enough to include computer models that simulate floodplain patch succession dynamics (Chiarollo *et al.*, 1998) and the effects of lotic system patch structure on dependent processes (D'Angelo *et al.*, 1997; Band *et al.*, 2000; Poole, 2000). Along with the application of landscape ecology principles to fluvial ecosystems has come a widely held view of fluvial landscapes as multiscaled nested hierarchies of interactive terrestrial and aquatic elements (Frissell *et al.*, 1986; Townsend, 1996), where elements are defined as the basic, relatively homogenous units (patches) observable within a landscape at a given spatial scale.

While the emerging fluvial landscape perspective recognises the need for integration across scales and existing disciplines (e.g. Fisher, 1997; Fisher, Grimm & Gomez, 1998; Wiens, 2002), fluvial landscape ecology has not yet developed as a distinct integrative field of study. As a discipline, fluvial landscape ecology would fulfil research needs by focusing on the integration of concepts such as pattern, process, hierarchy, scale, directionality and connectivity to derive relationships between system structure and system function in fluvial landscapes (Wiens, 2002). Although fluvial landscapes can contain elements that are usually more terrestrial than aquatic (e.g. floodplain patches, gravel bars, wood deposits), the foundational skills needed to address questions relevant to

fluvial landscapes are different from those needed to address terrestrial landscapes (Fig. 1). The differences are more than semantic. For instance, fundamentally different processes drive disturbance regimes in fluvial landscapes versus terrestrial systems. Therefore, although fluvial landscape ecology attempts to deal with issues similar to those found in terrestrial landscapes (Wiens, 2002), fluvial landscapes operate and structure themselves according to a particular set of rules (Townsend, 1996). Without careful consideration of the differences between fluvial and terrestrial

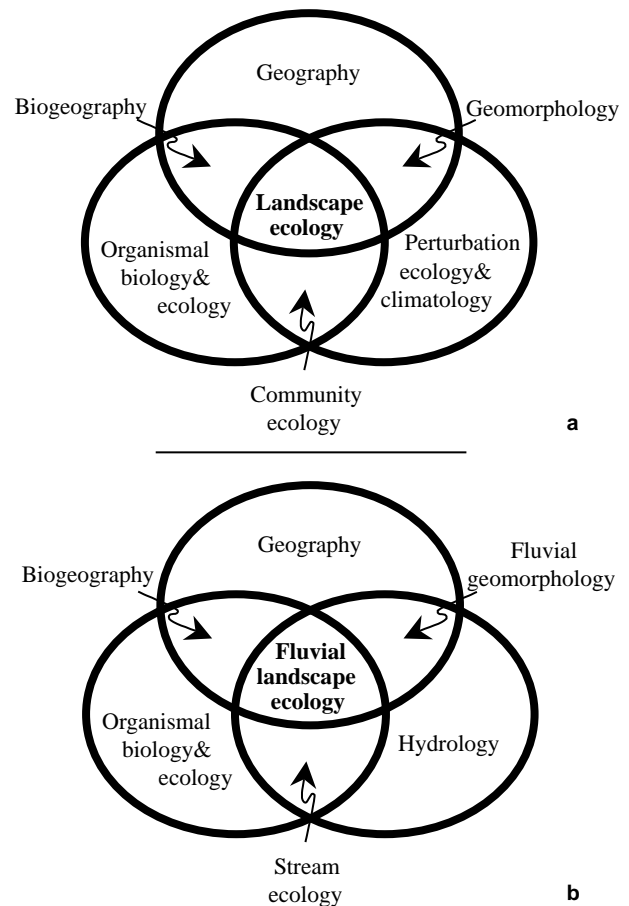

**Fig. 1** A comparison of foundational disciplines for (a) the fields of landscape ecology, and (b) fluvial landscape ecology. Hydrology, fluvial geomorphology, and stream ecology are the integral scientific underpinning of fluvial landscape ecology, making fluvial landscape ecology a fundamentally different field of study from landscape ecology.

landscape dynamics, direct application of tools developed for terrestrial landscapes may obfuscate rather than reveal underlying dynamics and relationships in fluvial landscapes. Therefore, the study of fluvial landscapes will require concepts and landscape analysis tools developed within a framework based on lotic ecosystem dynamics.

This paper presents a general framework for the discipline of fluvial landscape ecology. The framework combines patch dynamics (Turner, 1989; Forman, 1995) and hierarchy theory (Allen & Starr, 1982) by utilising a hierarchical patch dynamics (HPD) perspective (Wu & Loucks, 1995). The framework integrates and expands upon existing hierarchical classification schemes for surface (Frissell *et al.*, 1986) and ground-water (Dent, Grimm & Fisher, 2001; Malard *et al.*, 2002) components of lotic systems and, by building on Townsend's (1996) idea of a 'catchment hierarchy', provides a means for: (1) relating and integrating major concepts in lotic system ecology, (2) documenting and explaining the importance of interactions between landscape elements (patches) across spatial scales, and (3) guiding the development of the next generation of lotic ecosystem simulation models. The framework focuses on the fact that rivers form a patchy discontinuum from headwaters to mouth and attempts to integrate the ecological relevance of the discontinuum by highlighting the importance of uniqueness (Hynes, 1975) in fluvial landscapes.

### Hierarchical structure and trans-scale processes

Patterns and processes in lotic landscapes are strongly oriented to the direction of downstream water movement (Ward, 1989; Townsend, 1996). Directionality is so pervasive in lotic ecosystems that system structure and ecological connectivity within the system are generally divided into longitudinal, lateral and vertical vectors (Ward, 1989; Ward & Stanford, 1995).

At any point in the system, the patterns and processes occurring along each vector and the relative magnitude of each vector may be remarkably different. Townsend (1996) describes how the 'variation in linkage strengths within the catchment hierarchy' is driven by changes in the structure of patches along a river's downstream profile (see also Stanford & Ward, 1993; Ward & Stanford, 1995; Ward, 1997). Townsend (1996) further describes how the applicability of

different river ecology concepts changes with the relative magnitude of connectivity vectors – the river continuum concept (Vannote *et al.*, 1980; Sedell, Richey & Swanson, 1989) is applicable to constrained streams where longitudinal linkages are strong, but the flood pulse concept (Junk, Bayley & Sparks, 1989; Tockner, Malard, & Ward, 2000) and hyporheic corridor concept (Stanford & Ward, 1993) are appropriate in unconstrained reaches where geomorphological structure facilitates lateral and vertical linkages. The serial discontinuity concept (Ward & Stanford, 1983, 1995; Stanford, Hauer & Ward, 1988) also can be integrated into a catchment hierarchy because discontinuities are represented as boundaries between adjacent river segments that differ markedly in geomorphological structure and therefore connectivity. Importantly, rather than view the river as a continuum from headwaters to mouth, Townsend's (1996) 'catchment hierarchy' recognises that the downstream variation in stream segment structure ultimately determines the pattern of change in the extent of lateral and vertical connectivity along the river. From a catchment hierarchy view, it seems logical that rearranging the patches along a river's course will change the ecological dynamics of the system even if the relative proportion of patch-types in the system remains the same (Fisher *et al.*, 1998).

Within a patch hierarchy, several neighbouring landscape elements (patches) delineated at a given spatial scale will be amalgamated into a single *encompassing element* if observed at a coarser spatial scale. Similarly, any one of those original elements can be subdivided into several *component elements* if observed at a finer spatial scale (Forman, 1995). For instance, in Fig. 2, any stream reach is one of several adjacent reaches that resides within a specific stream segment (the reach's encompassing element), and always contains a collection of habitat units (the reach's component elements).

Processes, on the other hand, can span spatial scales. These *trans-scale* linkages (Fig. 3) create, modify, or destroy the structure or function of elements within the hierarchical patch matrix (Urban, O'Neill & Shugart, 1987; Pickett *et al.*, 1989). When processes are influenced by patch structure, juxtaposition or functions at coarse scales, but influence patch structure, juxtaposition or function at finer scales, they can be considered *top-down trans-scale* processes. Ecological disturbances (floods, fire, wind, etc.) are examples, because they are often

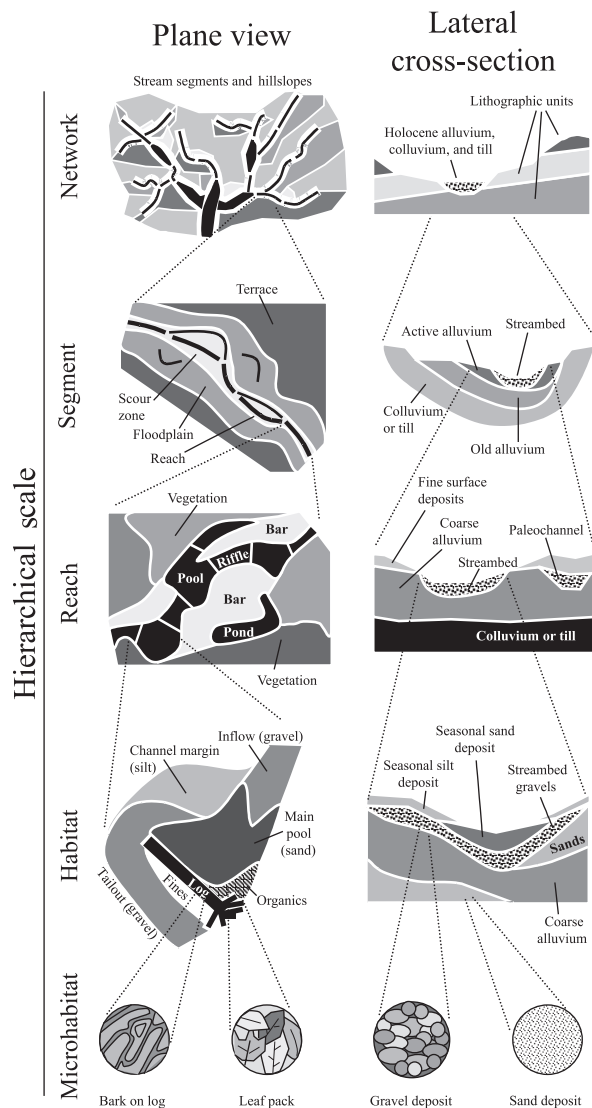

**Fig. 2** A three-dimensional patch hierarchy for lotic systems (based on Frissell *et al.*, 1986; Dent *et al.*, 2001). Labels for elements at each hierarchical level are merely illustrative because systems can be decomposed according to a variety of criteria (see O'Neill *et al.*, 1986).

influenced by the system's context (encompassing element structure), and influence the internal structure of the system (component element structure and juxtaposition). When processes are influenced by fine-scale patch structure, juxtaposition or function, but influence patch structure, juxtaposition or function at coarser scales, they can be considered *bottom-up trans-scale* processes. Succession within ecosystems is an example, e.g. a stand of trees on a floodplain (the encompassing element) is converted from a pioneer to

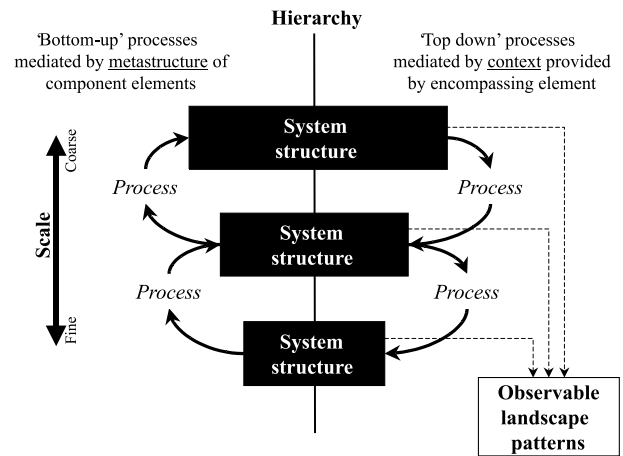

**Fig. 3** Top-down and bottom-up relationships between encompassing and component elements as mediated by *trans-scale* processes.

climax community by the replacement of individual trees (the component elements).

Ecologists have been articulating the importance of hierarchical linkages between ecosystem elements at different scales since at least the 1980s (e.g. Allen & Starr, 1982; Urban *et al.*, 1987; Turner, 1989) and those same concepts have more recently been applied to lotic ecosystems (Frissell *et al.*, 1986; Townsend, 1996; Allan & Johnson, 1997; Ward, 1997, 1998; Montgomery, 1999). Yet, the concepts have often been applied as a means of identifying the 'appropriate' scale at which to assess a given set of dynamics and understanding how the juxtaposition of patches at that scale may influence ecosystem dynamics. Functional linkages between patches *across* spatial scales have received light treatment.

On the other hand, fluvial geomorphologists began addressing *trans-scale* linkages several decades ago (e.g. Schumm, 1977; Church & Mark, 1980; Chorley, Schumm & Sugden, 1984). Recent trends towards finer-scale studies in geomorphology have been described as a shift from description to explanation (Lane, 1995; Lane & Richards, 1997), thereby underscoring the importance of bottom-up, *trans-scale* processes in geomorphology (e.g. Friend, 1993). Today, the concept of bottom-up and top-down *trans-scale* linkages provides a foundation for understanding geomorphological dynamics of fluvial landscapes and their interactions with biological communities (Montgomery, 1999; Poole, 2000). Many geomorphological studies and concepts now address dynamics and

structures at multiple spatio-temporal scales (e.g. Church, 1995; Bisson & Montgomery, 1996; Walsh, Butler & Malanson, 1998; Arscott, Tockner & Ward, 2000; Newson & Newson, 2000; Prosser *et al.*, 2001; Malard *et al.*, 2002).

Combining ecological and geomorphological perspectives on lotic ecosystem structure and function will result in improved but complex conceptualisations of fluvial landscape dynamics that integrate knowledge across disciplines and across spatio-temporal scales (e.g. Fig. 4). Ultimately, supporting or refuting the resulting conceptualisations will require us to identify and understand the functional *trans-scale* linkages between various ecosystem elements, and determine how the context, structure and juxtaposition of elements in the fluvial landscape influence those linkages.

In a patch hierarchy, the structure, arrangement and juxtaposition of a patch's component elements – a concept I term *metastructure* – is a critical factor determining the function and behaviour of the patch. Because metastructure refers to the spatial interrelationships among a group of elements, the concept can be applied to that group. However, the

concept is perhaps most useful when viewed as a distinct structural characteristic of the single element that encompasses those patches at a coarser scale. For example, we might consider the pattern of alternating canyon and floodplain segments observed within a stream network as the metastructure contained within the stream network. Similarly, an observed juxtaposition of habitat units contained within a stream reach is the metastructure contained within the reach.

The metastructure contained within an element will influence the function, character, or operation of that element within the landscape. As metastructure is altered by creating, modifying or destroying individual component elements, and because the persistence of individual component elements is typically shorter than that of the element itself (Table 1), the metastructure contained within an element is apt to be dynamic within the lifetime of the element, while other structural characteristics of the element may remain static. Thus, although an element may persist on the landscape for a given period of time, the ecological function of that element may change, in part as a function of bottom-up influences driven by

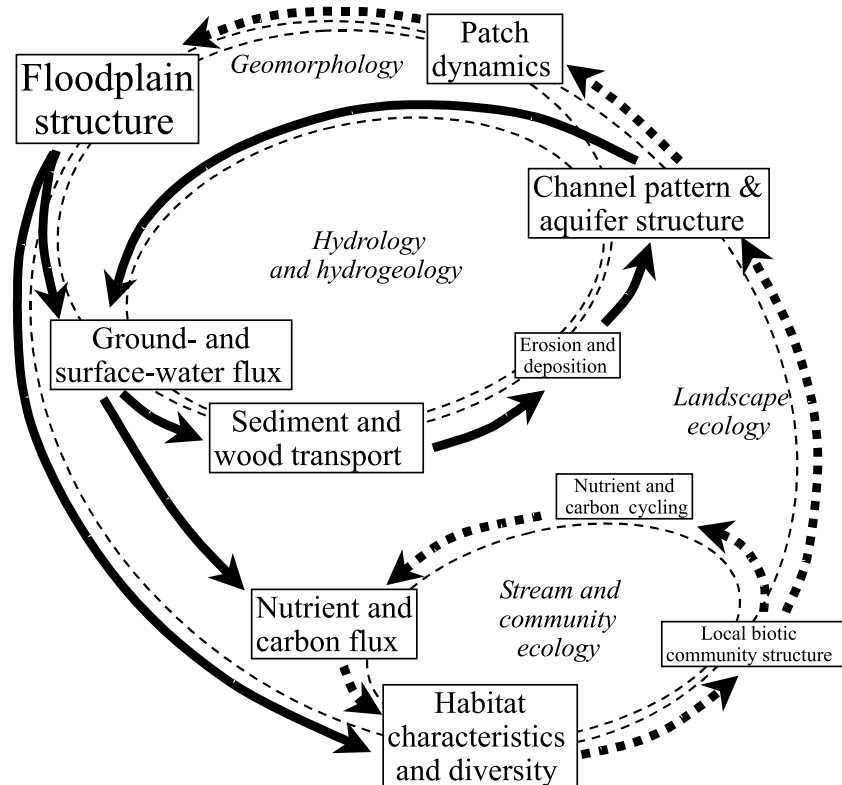

**Fig. 4** A conceptualisation of biocomplexity and fluvial landscape dynamics on river floodplains. Text size represents relative spatial and temporal scales; large text represents coarse spatial and long temporal scales, small text connotes fine spatial and short temporal scales. Solid arrows represent linkages driven predominantly by physical processes and dashed arrows represent biogeochemical interactions. Thin dashed ovals represent feedback mechanisms studied primarily by specific academic disciplines shown in italic text within each oval.

**Table 1** An element-based hierarchical view of lotic ecosystem structure (after Frissell *et al.*, 1986; see also Fig. 2). Scale refers to the approximate size of the hierarchical system and the frequency of disturbances that create and destroy the system

Hierarchical system	Scale	Concepts and application
System elements		
Stream network	10 <sup>3</sup> months	The stream network is viewed in the context of its catchment. Surface element boundaries are determined by dividing the catchment into areas dominated either by hillslope or fluvial processes. Aquifer elements are determined by catchment lithology, where Holocene alluvium is associated with the fluvial network and other lithographic units are associated with hillslopes. Comparisons among stream networks might focus network efficiency, species distributions/migrations, sediment sources and transport, etc.
Channel segments	10 <sup>5</sup> –10 <sup>6</sup> years	
Hillslopes		
Lithographic units		
Segment	10 <sup>2</sup> months	The channel, riparian zone, floodplain, and alluvial aquifer are viewed as a single, integrated fluvial corridor distinct from, but interacting with, the remaining catchment. Inundation frequency and duration determine surface element boundaries. Sediment source and water residence time in the aquifer determines aquifer element boundaries. Comparisons among segments might focus on water routing, relative importance of longitudinal, lateral and vertical connectivity, etc.
Channel reaches	10 <sup>3</sup> –10 <sup>4</sup> years	
Inundation zones		
Aquifer zones		
Reach	10 <sup>1</sup> months	The lotic ecosystem within the fluvial corridor is divided into its distinct components (channel, floodplain, vegetation, and alluvial aquifer), which are measured and studied as separate, but interconnected systems. Element boundaries are determined by coarse-scale geomorphological features such as islands, side-channels, cut-banks, and slope breaks. Aquifer units are determined by strata boundaries within the alluvial aquifer. Comparisons among reaches might focus on community structure and dynamics, habitat stability, etc.
Habitat units	10 <sup>1</sup> –10 <sup>2</sup> years	
Coarse geomorphic features		
Aquifer strata		
Habitat unit	10 <sup>0</sup> months	Lotic system components are divided into functional habitats (pools, riffles, bars, swales, natural levees, etc.), which are measured and studied as individual, but interactive features of the landscape. Element boundaries are determined by fine-scale topography. Individual lenses and deposits serve as aquifer units. Comparisons among habitat units might focus on resource utilization, competition, habitat selection, etc.
Microhabitats		
Fine geomorphic features	10 <sup>0</sup> –10 <sup>1</sup> years	
Lenses and deposits		
Microhabitat	10 <sup>-1</sup> months	The diversity within functional habitats is examined by measuring internal structural gradients and patchiness. Element boundaries are determined by changes in substratum type, character or position. Individual habitat features (rocks, logs, gravel patches, etc.) represent channel and floodplain elements, while small sediment volumes with similar physical structure, redox potential, nutrient availability, etc., represent aquifer elements. Comparisons among microhabitats might include nutrient availability, substratum preference, feeding habits, etc.
Aquatic habitat	10 <sup>-1</sup> –10 <sup>0</sup> years	
Terrestrial habitat features		
Local interstitial network		

changes in the metastructure contained within the element. Within a dynamic hierarchy, then, the concept of metastructure provides a means to describe the bottom-up processes that influence an element's ecological function, just as the more commonly used concept of context describes top-down influences on an element's function.

The utility of discerning top-down (contextual) influences from bottom-up (metastructural) influences is illustrated by Figs 3 and 4. The interplay between top-down and bottom-up processes forms feedback loops that operate across spatial scales within complex,

hierarchical systems. Thus, identifying top-down and bottom-up process facilitates functional descriptions of feedback loops, a critical step in understanding *trans-scale* dynamics and overall behaviour of complex systems (O'Neill *et al.*, 1986; Kay, 2000).

As the behaviour of each coarser-scale element within the hierarchy simultaneously influences and is influenced by the dynamics of finer-scale elements (Fig. 3), the concepts of context and metastructure provide a means for understanding how the unique multiscaled hierarchical physical structure of any river network may influence functioning of each nested

element within a lotic ecosystem as well as the lotic ecosystem as a whole (Townsend, 1996). For instance, cumulative effects of land use on in-stream habitat (e.g. Cedarholm, Reid & Salo, 1981; Bisson *et al.*, 1992; Megahan, Ptoyondy & Seyedbagheri, 1992; Roth, Allen & Erickson, 1996; Allan *et al.*, 1997) can be viewed as a problem involving linkages across spatial scales; first bottom-up (identifying and documenting the additive or synergistic effects of individual land use activities on stream networks) and then top-down (understanding how the resulting changes across stream networks affect site-specific habitat conditions within the stream). Understanding these types of spatially explicit, hierarchical relationships and developing tools to study them provides an appropriate focus for the 'fluvial landscape ecologist' and may ultimately engender a view of lotic ecosystems that specifically incorporates the concepts of context, metastructure and uniqueness into our basic view of fluvial systems.

### A hierarchical patch dynamics view

Addressing *trans-scale* linkages in lotic ecosystems requires a formal framework for integrating the concepts of patch mosaics and dynamics from landscape ecology with concepts derived from hierarchy theory. Current understanding of patch mosaics and patch dynamics has been developed by landscape ecologists predominantly by studying terrestrial and intertidal ecosystems at specific spatial scales (Levin, Steele & Powell, 1993; Forman, 1995). The patch dynamics perspective decomposes landscapes into elements (patches), which are 'relatively homogeneous unit[s] recognised in a mosaic at any scale' (Forman, 1995).

Hierarchy theory has been developed as part of general systems theory (Pattee, 1973). Systems ecologists have applied the theory to understand and explain ecosystem behaviour (Allen & Starr, 1982; O'Neill *et al.*, 1986). Hierarchy theory decomposes systems into nested subsystems, often based on differences in process rates between the subsystems (O'Neill *et al.*, 1986). Each subsystem can be considered a complete system when viewed at a finer spatial or temporal scale within the hierarchy.

Wu & Loucks (1995) describe a HPD perspective, which melds patch dynamics and hierarchy theory. The HPD perspective views ecological systems as nested, discontinuous hierarchies of patch mosaics

(Kotliar & Wiens, 1990; Holling, 1992). This view provides an excellent framework for understanding and studying *trans-scale* linkages in fluvial landscapes and a more formalised hierarchical construct for applying relevant concepts such as Townsend's (1996) catchment hierarchy, Poff's (1997) landscape filters and Montgomery's (1999) process domains.

A widely applied hierarchical classification of lotic ecosystems (Frissell *et al.*, 1986) can be expanded based on the HPD perspective to include both terrestrial and aquatic components of fluvial landscapes and integrated with the hierarchy of surface- and groundwater exchange described by Dent *et al.* (2001). This results in a hierarchical, spatially explicit, three-dimensional fluvial landscape classification scheme (Fig. 2, Table 1) that is dynamic with time. The classification scheme incorporates aquatic, terrestrial and subsurface landscape elements, thereby providing a means of formally integrating critical aspects of lotic ecosystems – including hierarchy, structure, *trans-scale* processes and directionality – with patch dynamics and other concepts from landscape ecology.

The HPD perspective can be envisioned using a hierarchy of element (patch) mosaics linked by *trans-scale* physical and biological processes (Fig. 5). Individual landscape elements (middle) are shown below their encompassing element and above a component element. If the middle elements in Fig. 5 represent

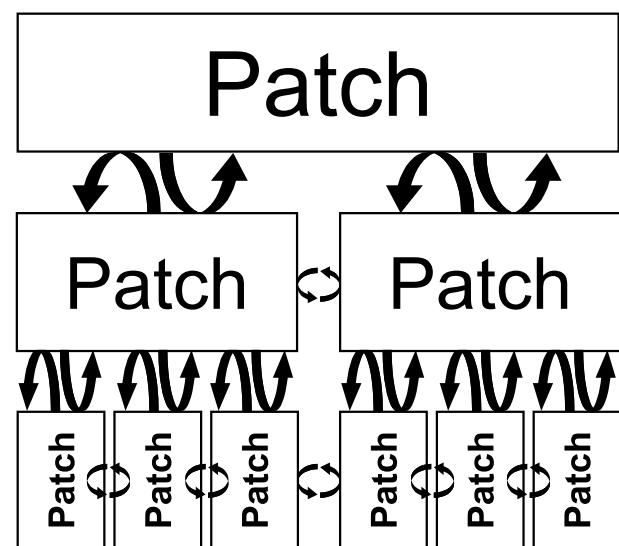

Fig. 5 A dynamic patch hierarchy. Each row represents the same landscape divided into patches at different spatial scales. Arrows represent processes that create interactions and feedbacks between patches both within and across scales.

stream reaches, the encompassing element would be a stream segment and the component elements a collection of floodplain and channel habitat units (pool, riffle, bars, etc.; Table 1; Fig. 2).

When representing a lotic ecosystem as a hierarchical patch mosaic, the physical structure of any element is influenced both by the structural context provided by the encompassing element and by the metastructure of component elements (e.g. hierarchical interactions described by Maridet *et al.*, 1998; Montgomery *et al.*, 1999; Baxter & Hauer, 2000; Pinay *et al.*, 2000; Rot, Naiman & Bilby, 2000; Dent *et al.*, 2001; Heritage, Charlton & O'Regan, 2001; Ward & Tockner, 2001). Structural context wholly determines some structural characteristics of an element, but merely limits the expressed range of other characteristics. For example, from the time the overall structure of a stream reach is created to the time it is destroyed, the slope of the reach (a structural characteristic) is often fixed by the structural context provided by the encompassing stream segment. In contrast, within the same time frame, the streambed topography, local sinuosity, width and depth of a reach will be constrained by structural context, but may vary spatially and temporally within those constraints. The precise expression of these variable characteristics is strongly influenced by the metastructure contained within the element (e.g. the local sinuosity, width and depth of a stream reach are influenced by the juxtaposition and structure of component channel and floodplain habitat units within the reach).

The HPD perspective (Wu & Loucks, 1995) is well suited to addressing hierarchy, structure, *trans-scale* dynamics, and directionality in lotic ecosystems. Stream networks can be decomposed into a hierarchy of structural elements in three dimensions (e.g. Fig. 2). At any one scale, individual elements are influenced by the interplay between their context (provided by the encompassing element), the metastructure of component elements, and the *trans-scale* processes that link the structures within the hierarchy (Kay, 2000). The flexibility and generality of this view is illustrated by Fig. 6, where the ecosystem dynamics described by existing concepts in stream ecology are diagrammed using *trans-scale* processes that link elements within physical and biotic community hierarchies.

While Fig. 6 represents an over-simplification of the diagrammed concepts, the figure reveals relationships between these concepts that otherwise are not

obvious. For instance, while the river continuum concept, serial discontinuity concept, flood pulse concept and hyporheic corridor concept all make predictions about ecological connectivity and biotic response as a function of physical stream structure, they address these interactions at different spatial and temporal scales within the hierarchy. The river continuum concept and serial discontinuity concept address community structure as a function of longitudinal connectivity at the same hierarchical scales (network and segment scales). In both concepts, longitudinal connectivity is influenced by transitions in stream structure that occur between stream segments. A major difference, however, is that the river continuum concept assumes that the stream segment metastructure contained within the network forms a continuum, while the serial discontinuity concept focuses on those abrupt transitions between adjacent stream segments with dissimilar physical structure (e.g. canyon to floodplain, lake or reservoir to stream). In contrast, the flood pulse concept and the hyporheic corridor concept address lotic ecosystem function at finer spatial scales (segment to habitat unit) and focus on lateral and vertical connectivity as drivers of community structure and dynamics.

Once each concept's vectors and scales are explicitly identified, the four concepts fit together to illustrate how context, structure and metastructure of hierarchical elements within the stream network influence ecosystem dynamics by determining the relative importance of longitudinal, lateral and vertical connectivity at any given location across a number of spatial scales [Fig. 7a; see Townsend (1996) for further discussion]. Fig. 7a presents an integration of stream ecology concepts that suggests reach-scale community structure is influenced by carbon and nutrient dynamics upstream, on the floodplain and in the groundwater. Biogeochemical processes driving these dynamics occur across multiple spatial scales. The biological community structure in a stream segment is driven by the forms of carbon and nutrients delivered along longitudinal, lateral and vertical connectivity vectors (solid arrows, Fig. 7b), but the relative importance of each vector at any point in the stream network is influenced by the physical structure of the stream at multiple scales (dashed arrows, Fig. 7b). This suggests that a stream segment's physical context, structure and metastructure are important considerations for understanding which connectivity



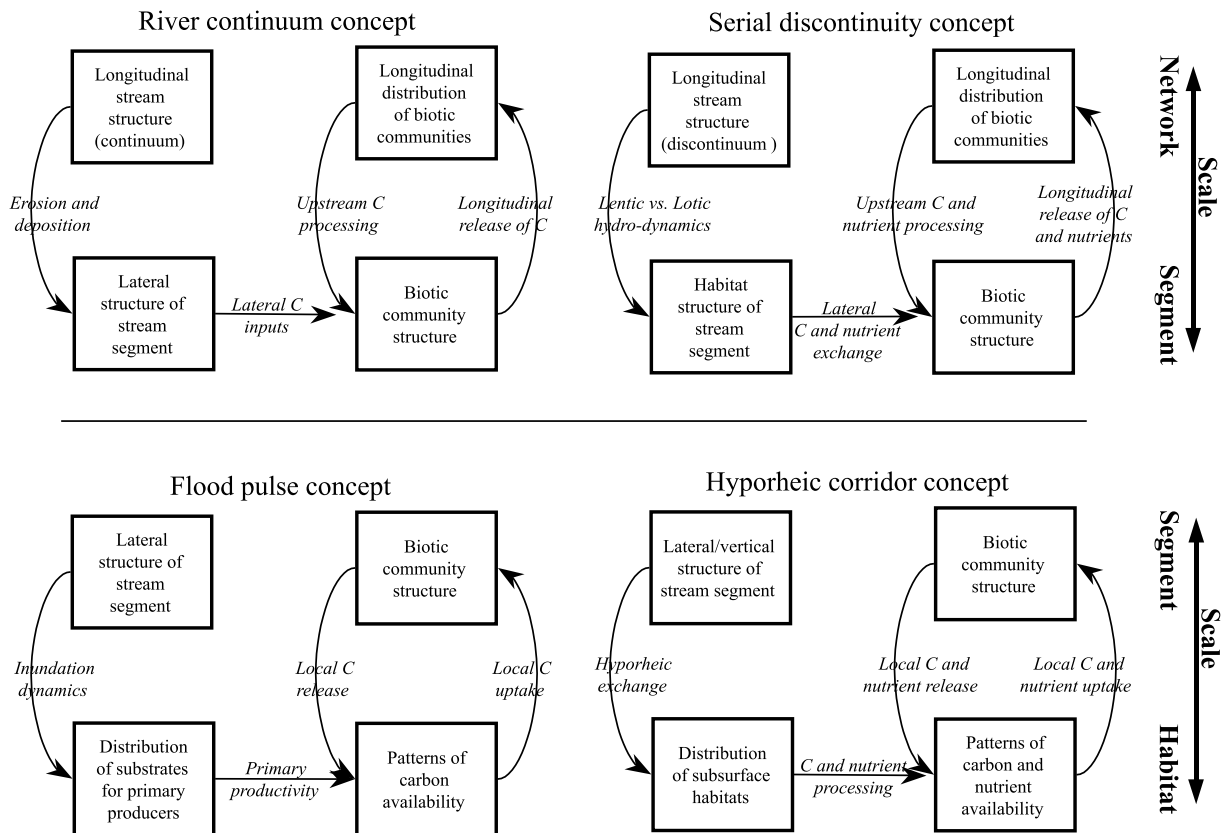
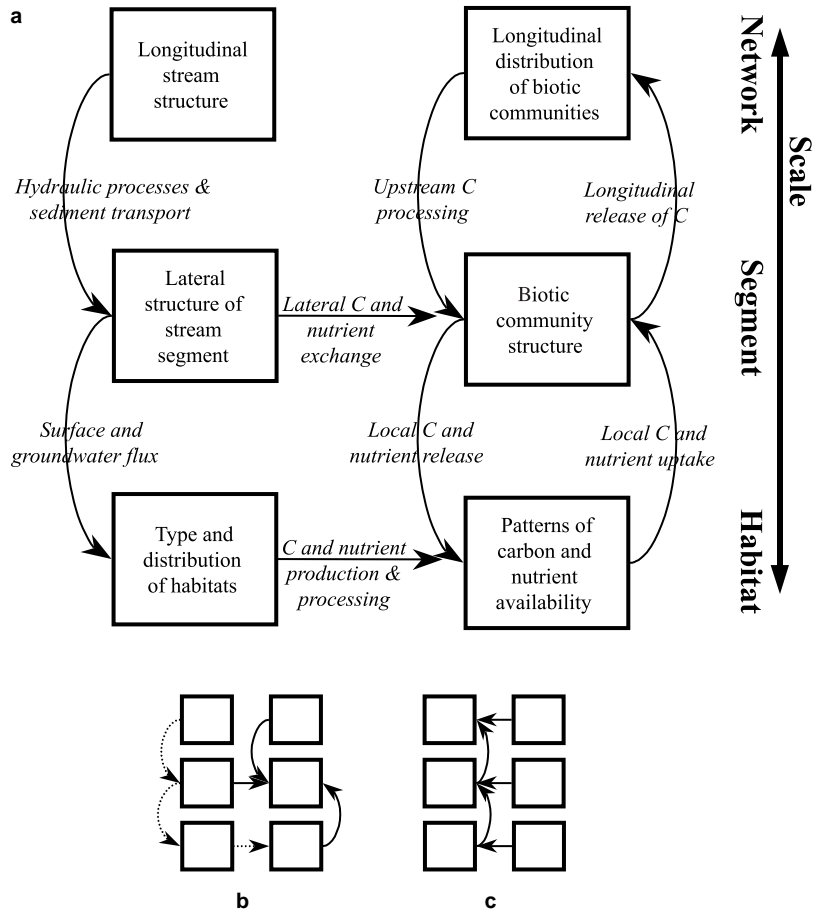

Fig. 6 Common conceptual models in stream ecology diagrammed using *trans-scale* processes that link physical structures and biological community structures across spatial scales.

vectors (lateral, longitudinal, or vertical) will be primary drivers of biotic community composition at any location within the stream. Therefore, the context, structure and metastructure of a stream segment will determine when and how well the different concepts in stream ecology will apply to the stream segment (Townsend, 1996). Simply put, when a stream's structure encourages lateral or vertical connectivity (e.g. floodplain systems), aquatic communities are apt to be structured by lateral and vertical processes such as those described in the flood pulse concept and the hyporheic corridor concept. When the physical structure of a stream limits lateral and vertical connectivity (e.g. bedrock confined system), aquatic communities are apt to respond to upstream processing, as described in the river continuum concept and serial discontinuity concept. These stream ecology concepts, however, highlight different ends of various spectra. In reality, most stream networks contain segments that alternately inhibit or enhance lateral and vertical connectivity. Fig. 7b suggests that biotic communities

will respond in complex and interdependent ways to downstream and localised *changes and variation* in lateral, vertical, and longitudinal connectivity (e.g. Ward *et al.*, 1998; Ward & Tockner, 2001). Although variation in connectivity vectors occurs over multiple time-scales, the physical template of the stream system mediates this variation. If the physical template can be described and understood by defining the context, structure and metastructure of elements within each stream's unique physical hierarchy, complex biotic community responses might be explained.

The arrows shown in Fig. 7c (i.e. those missing from Fig. 7a) suggest that bottom-up influences in the physical hierarchy and biological feedback that affect stream structure are not addressed by the river continuum concept, serial discontinuity concept, flood pulse concept and hyporheic corridor concept. Even so, many examples of these linkages are understood well. As described earlier, geomorphologists have documented bottom-up physical dynamics in stream channels that ultimately influence channel pattern and



**Fig. 7** (a) Combined diagram of common conceptual models in stream ecology (from Fig. 6). (b) Direct (solid lines) and indirect (dashed lines) influences on biotic community structure. (c) Linkages missing from common conceptual models in stream ecology.

network structure. Similarly, the roles of large woody debris (Sedell & Froggatt, 1984; Triska, 1984; Gurnell *et al.*, 2002), beaver (*Castor canadensis*) (Naiman, Johnston, & Kelley, 1988) and even biological perturbation (Ward *et al.*, 1998) in structuring stream environments are examples of how biotic communities affect the physical structure of a stream that are essentially ignored by current stream ecology concepts. Fig. 7 illustrates how a HPD view of fluvial landscapes provides an opportunity to build upon existing concepts in river ecology, integrate additional knowledge from stream ecology and other disciplines (especially the critical influences of bottom-up linkages) and understand how each stream's unique patch hierarchy will ultimately affect that stream's ecology.

### The river discontinuum

A continuum is defined as 'a continuous extent, succession, or whole, no part of which can be distinguished from neighbouring parts except by

arbitrary division' (*American Heritage Dictionary of the English Language*, 3rd edn, 1992. Houghton Mifflin Company). While a continuum from headwaters to mouth (Vannote *et al.*, 1980) is a reasonable representation of a stream in general, no specific river is a continuum. At any spatial scale, rivers are routinely divided into discrete parts based on non-arbitrary distinctions (e.g. Fig. 2). Further, in a river network, tributary junctions create 'gaps' in the expected downstream succession of habitats (Rice, Greenwood & Joyce, 2001; Church, 2002). Where two streams of approximately the same size meet, downstream habitat succession suddenly skips to a new trajectory as the stream size doubles. Where a small stream meets a large stream, the downstream habitat succession of the small stream jumps ahead toward that of the large stream, skipping over habitats typical of intermediate streams. As discussed earlier, stream ecologists have recognised the potential importance of resulting discontinuities (e.g. Sedell *et al.*, 1989; Stanford & Ward, 1993; Townsend, 1996). Yet, in part because a river's

physical template is generally viewed as a continuum, ecologists sometimes recognise the importance of discontinua and metastructure conceptually, but fail to incorporate the concepts into testable hypotheses, research design, site selection methods, or data analyses (but see Rice *et al.*, 2001 for a notable exception). Ultimately, our failure to embrace spatial heterogeneity and fluvial dynamics as critical characteristics of lotic systems may be contributing to Fisher's (1997) observed lag in the rate of new idea generation (Ward & Tockner, 2001).

The HPD perspective represents the physical template of a stream as a network of dynamic discontinua comprised of hierarchical patches. Therefore the HPD perspective is useful for studying and understanding patterns and processes observed in individual river systems. While the continuum view of rivers assumes that the structure or function of a stream segment will always be most similar to that of neighbouring segments, a discontinuum view makes no such assumption. At the network scale, a discontinuum view assumes that the individual stream segments are ecologically connected in the longitudinal dimension, but that the longitudinal arrangement of segments within every stream network is unique and dynamic over time (e.g. Rice *et al.*, 2001). However, a discontinuum view does not reject the continuum view so much as subsume it; in some cases, the patchy arrangement of segments will happen to contain gradual transitions between elements and will approximate a continuum of conditions.

Viewing a stream as a discontinuum comprised of hierarchically nested patches has important implications for how we perceive stream structure, conceive hypotheses and design studies of lotic ecosystem dynamics. For instance, two predictions about discontinuities in stream systems can be derived from a HPD perspective, and both can be tested using a simple model designed to represent a patch hierarchy. Because stream networks provide the physical context for stream segments and any discontinuities between segments, the HPD perspective predicts:

P1: Ecological responses to discontinuities will vary depending on the location of the discontinuity along the longitudinal profile.

Notably, Ward & Stanford (1983, 1995) arrived at this same conclusion from empirical observations. Additionally, discontinuities between stream seg-

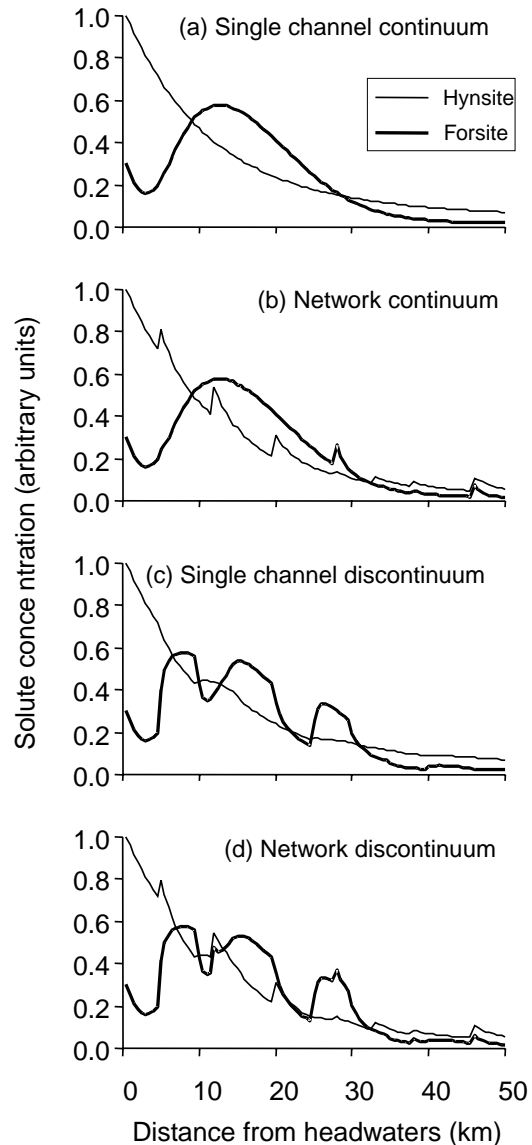

**Fig. 8** Results from four modelling scenarios simulating concentrations of hypothetical solutes (Hynsite and Forsite) along a downstream profile. Single channel scenarios (a, c) assume no tributaries along the downstream profile while network scenarios (b, d) incorporate the effects of tributaries (see Fig. 11). Continuum scenarios (a, b) assume a continuous gradient of physical characteristics from headwaters to mouth while discontinuum scenarios (c, d) incorporate the effects of stream segment metastructure contained within the downstream profile (Fig. 12).

ments occur when there is an abrupt change in the lateral structure (and connectivity) of the stream along the longitudinal profile. Thus, we can predict:

P2: Ecological dynamics strongly influenced by lateral and vertical connectivity within segments

should have strong responses to serial discontinuities, while ecological responses driven mostly by longitudinal dynamics should have relatively weak responses to serial discontinuities.

A simple model illustrates how physical context, structure and metastructure mediate the relative importance of connectivity vectors, and can therefore substantively influence longitudinal patterns of biological communities in a hypothetical system similar to a river network. The model is purely heuristic and is not intended as a realistic simulation of lotic ecosystem dynamics. Nevertheless, it illustrates how elements of the river continuum concept, serial discontinuity concept, flood pulse concept and hyporheic corridor concept might be mechanistically integrated and applied using the HPD perspective to study a unique river discontinuum.

In the model, concentrations of two biologically important solutes are simulated along a river corridor using simple equations (Appendix). The first solute is *Hynsite* (the biologically available form of *Hynsium*, a hypothetical element named for the river ecologist H.B.N. Hynes). *Hynsite* dynamics are driven by catchment processes and longitudinal interactions. *Hynsite* is delivered in solution from the surrounding basin at high concentrations, and is taken up by biota

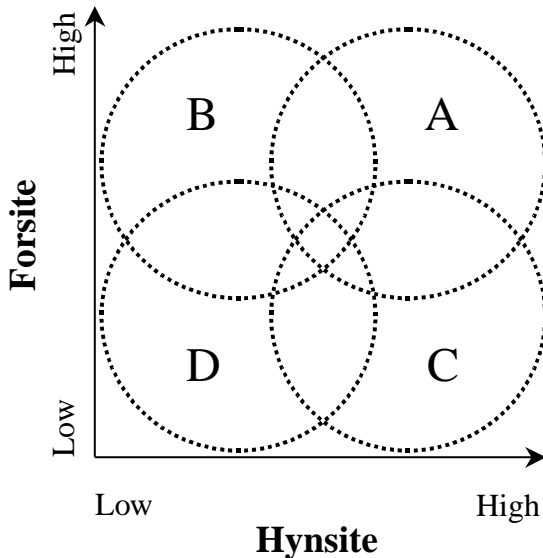

Fig. 9 Niches for four species of aquatic insects (A–D) relative to Hynsite and Forsite concentrations (e.g. species A is most abundant where concentrations of Hynsite and Forsite are high but species D is most abundant where concentrations are low).

within the river channel. Thus, longitudinal connectivity drives Hynsite concentrations, and Hynsite concentrations decay along an idealised river continuum (Fig. 8a).

The second solute is *Forsite* (the biologically available form of *Forsium*, a hypothetical element named for the landscape ecologist R.T.T. Forman). *Forsite* dynamics are driven by lateral connectivity within stream segments. Only a small fraction of *Forsium* delivered to the stream from the catchment arrives as *Forsite*. However, where lateral and vertical connectivity are high, interactions between fluvial landscape

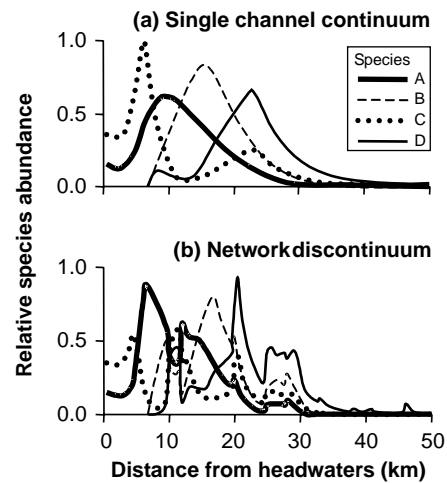

Fig. 10 Distributions of four hypothetical species (see Fig. 9) along the downstream profile based on predicted Hynsite and Forsite concentrations (see Fig. 8).

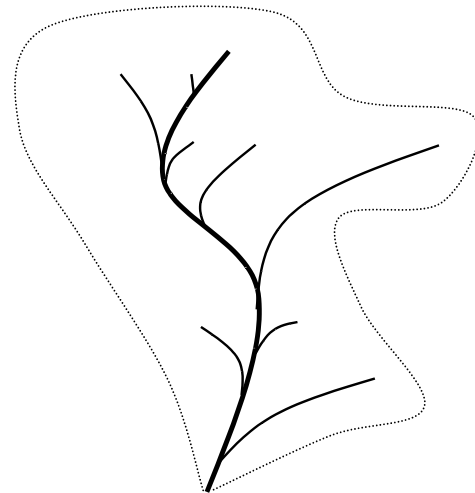
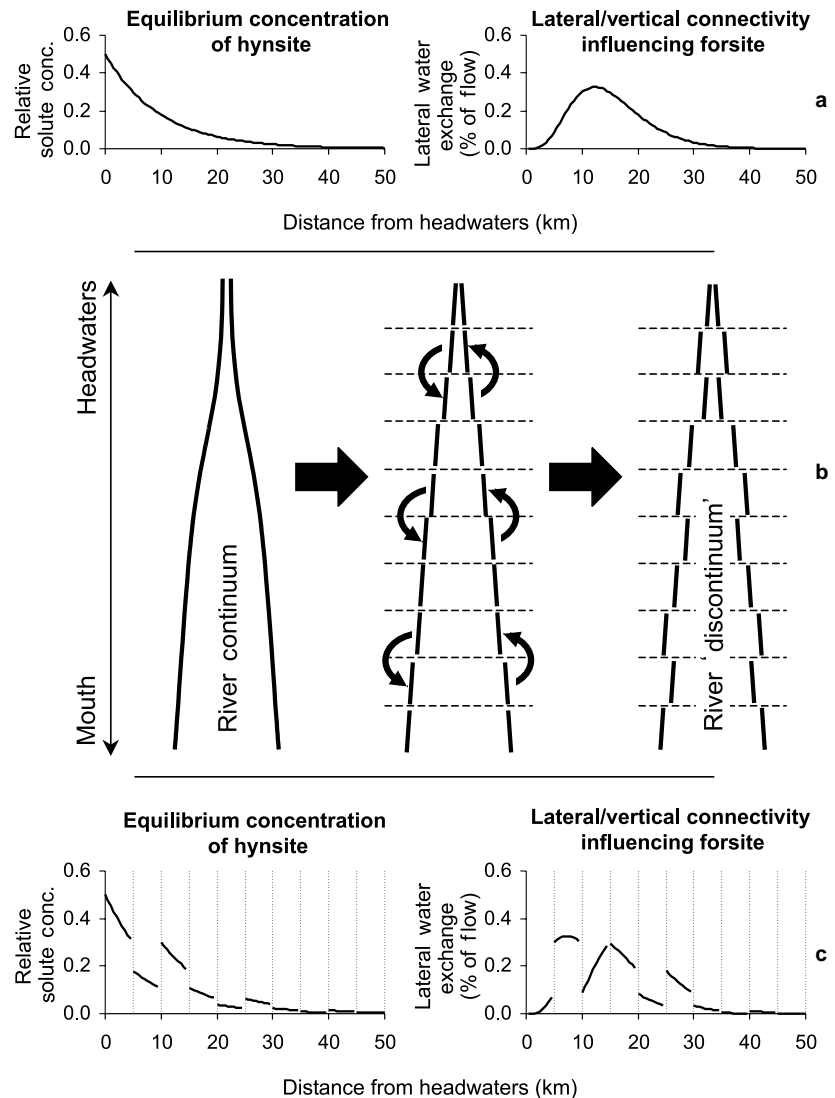

Fig. 11 A simple network branching pattern applied to the Hynsite/Forsite model.



**Fig. 12** Hypothetical equilibrium solute concentrations and connectivity patterns along a river continuum vs. a river discontinuum. The equilibrium concentration for a length of stream is the concentration that would not be altered as water passes through the length of the stream. Hynsite dynamics are most strongly influenced by longitudinal connectivity and Forsite by lateral connectivity (see text). (a) Assuming a gradual continuum along the river corridor, Hynsite equilibrium concentrations would be the highest in headwaters, where longitudinal biological processing is least efficient (Vannote *et al.*, 1980), whereas lateral and vertical connectivity are enhanced in alluvial floodplains of middle reaches (Ward & Stanford, 1995). (b) By dividing the continuum into segments and reordering those segments, an alternative metastructure (a discontinuum) is created within the stream. (c) Based on the discontinuum metastructure, the pattern of equilibrium concentration and lateral connectivity along the stream would also be discontinuous.

elements on floodplain and in the hyporheic zone convert other forms of Forsium to Forsite. Therefore, along an idealised river continuum, Forsite concentration is highest in the middle reaches of the stream network, where floodplains have developed (enhancing lateral connectivity), but where fine sediments do not yet accumulate (maintaining vertical connectivity; Fig. 8a).

Four hypothetical species of aquatic insects respond to conditions influenced by the concentrations of Hynsite and Forsite (Fig. 9). Therefore, the concentration of Hynsite and Forsite can be used to determine the expected distribution of these insect species along an idealised river continuum (Fig. 10a).

By incorporating a network-type stream structure into the model (Fig. 11), the model can address the

effects of discontinuities caused by tributary streams and simulate how Hynsite and Forsite concentrations in the main channel are affected by branching pattern (Fig. 8b). Similarly, by rearranging the order of stream segments along the main channel (Fig. 12b), the downstream patterns of factors influencing solute dynamics are changed (Fig. 12a versus 12c), and the model predicts how changes in the metastructure contained within the river system can affect expected patterns of solute concentration (Fig. 8c). When network structure (branching pattern) and metastructure are considered simultaneously, both the patterns of Forsite and Hynsite (Fig. 8d) and the resulting pattern of insect distributions (Fig. 10b) are strikingly different from that predicted using a classic river continuum as the habitat template.

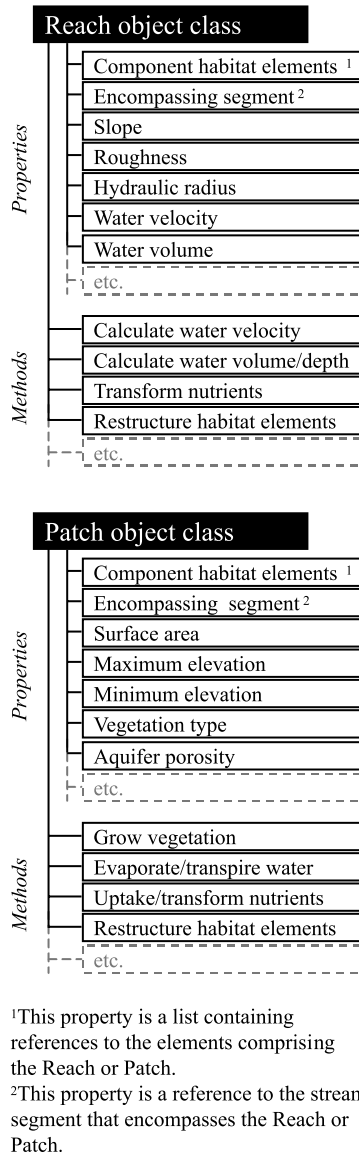

**Fig. 13** A conceptual schematic of programming objects representing stream reaches and floodplain patches.

The results of this simple model agree with the predictions (P1 and P2) outlined above. Simulated solute responses to serial discontinuities were more pronounced in the upper end of the catchment than in the lower end, confirming that ecological response to serial discontinuity may be dependent on the location of the discontinuity within the stream network. Further, Forsite was relatively unaffected by network structure, but highly influenced by metastructure (serial discontinuities) while the reverse was true for Hynsite, confirming that ecosystem processes

influenced by lateral and vertical connectivity will be especially responsive to serial discontinuities. Finally, the predicted variability in aquatic insect community structure (Fig. 10b) suggests that incorporating the concepts of context, structure, and metastructure into the theoretical foundation of lotic system ecology may ultimately help to explain the complex biotic community patterns observed in the field (e.g. Rice *et al.*, 2001).

While this simple model illustrates how context, structure and metastructure may be influential, more realistic ecosystem models are needed to simulate the spatial and temporal dynamics of lotic ecosystems (Wu & Loucks, 1995). Recently, ecosystem models have utilised object-oriented modelling approaches, which are especially compatible with the HPD perspective. Object-oriented modelling has its roots in object-oriented programming, a relatively recent departure from traditional computer programming techniques. Object-oriented computer programmes are developed as collections of programming objects, which are structured collections of information stored in a computer's memory (Fig. 13).

When a programming object is created in the computer's memory, the object is assigned to one of several object classes. The object's class determines the format of the information contained within the object, thus providing an interpretative key for the object's information. For instance, two object classes developed to model patch dynamics on a floodplain segment of a river might be called 'reach' and 'patch' and would represent a stream reach and a vegetation patch, respectively, in the model. The object structure associated with the 'reach' and 'patch' classes would be designed to contain information necessary to describe a stream reach or vegetation patch on the floodplain (Fig. 13).

Information contained within a programming object can be categorised as either a *property* or a *method*. The *properties* of an object describe the object's characteristics (i.e. structure) and can be either static or dynamic over the course of a simulation. For example, an object representing a stream reach has properties including slope, hydraulic radius, roughness, water velocity and water depth. *Methods* associated with an object are programme subroutines that use the properties of an object to simulate the object's behaviour (i.e. ecological function). Methods associated with a stream reach might include subroutines

**Table 2** Three lotic ecosystem models based on object-oriented modelling approaches

Model (References)	Description
GEOMOD (D'Angelo <i>et al.</i> , 1997)	GEOMOD simulates the biological response to habitat unit metastructure contained within stream reaches. It describes reaches as composites of habitat units, documents the physical structure of each habitat unit, simulates carbon dynamics between three trophic levels of the food web based on the structure of the habitat unit and the longitudinal connectivity between units, and then predicts the pattern of carbon distribution among trophic levels along the stream reach.
RIFLS (Poole, 2000)	RIFLS simulates floodplain inundation, surface- and groundwater flow, and hyporheic exchange in three dimensions within a stream segment. RIFLS describes channel reaches, floodplain inundation zones, and aquifer zones as elements that combine to determine the structure of a stream segment. The model structure permits representation of heterogeneous anisotropic conditions in the alluvial aquifer. Whole-floodplain water flux is modeled as an emergent property of interactions between the hydrologic properties of each element, the metastructure of the elements, the structure of the floodplain, and spatial and temporal pattern of water delivery to the floodplain.
RHESSys* (Band <i>et al.</i> , 1993, 2000; Nemani <i>et al.</i> , 1993; MacKay & Band, 1997)	RHESSys simulates carbon and nitrogen dynamics and water flux in terrestrial ecosystems. The model has evolved sufficiently, however, to converge with lotic ecosystem modeling at the stream network scale. It describes stream networks as a five tiered dynamic patch hierarchy spanning the entire range of scales outlined in Table 1 and Fig. 2 (though the finer-scale RHESSys hierarchical elements are designed to represent elements nested with hillslope rather than channels). Nutrient and carbon cycling and transformation are modeled within soil and canopy strata and transported within the catchment via interaction between patches at and across each scale of the hierarchy. Thus, network-scale nutrient dynamics are modeled as emergent properties of dynamics occurring at no less than four distinct hierarchical levels nested within a stream network.

\*Although RHESSys is a terrestrial ecosystem model, it is included here because it uses an object-oriented approach to route water on hill slopes and in channels at the stream network scale (Table 1, Fig. 2); see also Fisher (1997) for rationale extending aquatic ecosystem boundaries to ridge tops.

that calculate water inflow and outflow, nutrient transformations, or erosion and deposition. Some methods determine how an object changes over time by altering the properties of the object during a simulation. In order to model interactions between objects (e.g. elements of a landscape), methods often alter the properties of an object based on the properties of other objects. For instance, the amount of water flowing into a stream reach is determined in part by the river stage in the reach directly upstream. Thus, the volume of water in a stream reach during a simulation time-step is dependent in part on the volume of water in the upstream reach in the previous time-step, thereby creating a functional linkage between modelled objects.

Objects may contain references to other objects within their list of properties (see footnotes in Fig. 13). Thus, a stream reach object may contain references to other objects representing specific habitat units, such as pools, riffles and bars contained within the reach. Nested objects (in this case, landscape elements) within the computer model accurately represent

relationships across hierarchical levels that confer physical context, structure and metastructure to landscape elements. Further, object-oriented models can simulate the ecological ramifications of changes in context, structure and metastructure simply by altering the properties of individual programming objects. Just as in real systems, changes in the properties of a single object will ripple through the simulation model and across spatial scales, resulting in changes in context or metastructure of landscape elements at other spatial scales.

There are at least three examples of lotic ecosystem models that illustrate application of an object-oriented HPD perspective to study reach, segment or network scale hydrology or ecology or both (Table 2, Fig. 14). However, none of the models fully implements the object-oriented approach described above. For instance, GEOMOD (D'Angelo *et al.*, 1997) does not simulate ecosystem dynamics within alluvial ground water. RIFLS (Poole, 2000) takes a fully object-oriented modelling approach conceptually, but does not use object-oriented programming. The latest version of

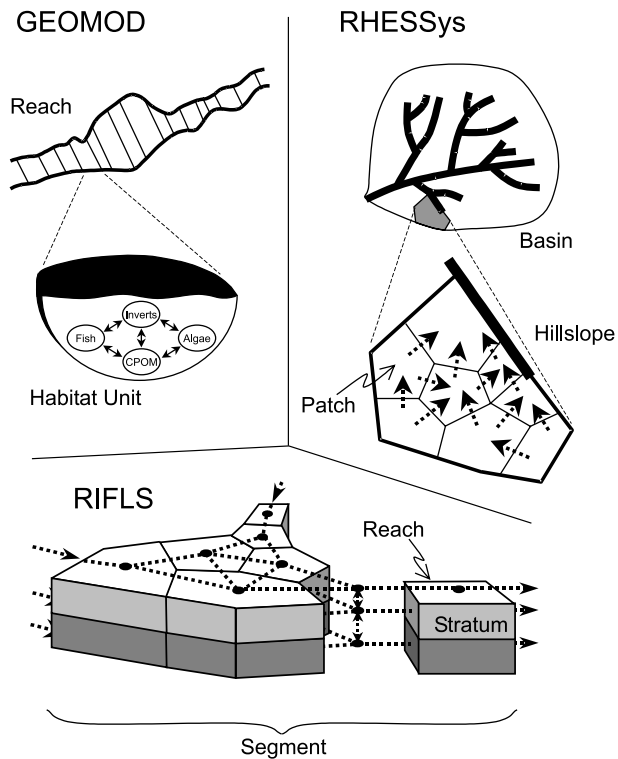

**Fig. 14** Schematics of approaches used to represent patch hierarchies in the simulation models GEOMOD, RIFLS, and RHESSys. Dashed lines represent water movement. This figure is derived from illustrations presented by D'Angelo *et al.* (1997), Band *et al.* (2000) and Poole (2000).

RHESSys (Band *et al.*, 2000) fully implements a hierarchical, object-oriented modelling approach for hill slopes, but represents the stream network as an absorbing boundary between hill slopes rather than as a dynamic ecological system. However, in spite of these limitations, each of these models illustrates the utility of the HPD perspective for conceptualising, studying, modelling and understanding dynamic linkages between patches and across spatial scales in lotic ecosystems. Combined, GEOMOD, RIFLS, RHESSys and the simple model presented here (Appendix) illustrate how the HPD perspective and the concepts of context, structure and metastructure provide an useful framework for the development of complex computer simulations. Such simulations will undoubtedly be critical for improving understanding of interactions between patterns and processes across scales within hierarchically structured fluvial landscapes, including the importance of the longitudinal discontinuum unique to each stream.

## Conclusions

Lotic ecosystems are patchy and strongly hierarchical. One of the challenges faced in developing improved understanding of fluvial landscapes is the melding of patch dynamics and hierarchy theory with existing tenets of lotic system ecology. As the nexus between ecology, geography and hydrology (Fig. 1), development of fluvial landscape ecology as a discipline holds promise for addressing these challenges. Since the patch structure of some river corridors is highly dynamic over the life span of an individual researcher, fluvial landscapes may serve as useful natural laboratories for integrating concepts of landscape ecology with those derived from hierarchy theory. Thus, although the emerging field of fluvial landscape ecology has to date borrowed heavily from the field of landscape ecology, the younger discipline may begin providing substantial new insights.

The HPD perspective provides a flexible and robust conceptual framework for fluvial landscape ecology because it views lotic ecosystems as a discontinuum of hierarchically nested and interactive elements. Specifically, the HPD perspective can: (1) integrate existing concepts from stream ecology, (2) address interactions between system elements within and across spatial scales using the concepts of context, structure and metastructure within a hierarchy and (3) yield specific guidance for the development of computer simulation models by underscoring the benefits of object-oriented modelling.

Within the context of fluvial landscape ecology, Hynes' (1975) commonly cited message still resonates: 'In every respect, the valley rules the stream.' In other words, context matters. Yet, for the fluvial landscape ecologist, a second message from Hynes' lecture emerges as equally important: 'Every stream is likely to be individual.' In other words, metastructure matters. This second message is crucial because the HPD perspective starts with the premise that every lotic system is a unique discontinuum of hierarchically arranged habitat transitions at multiple spatial scales. The HPD perspective further assumes that many system dynamics cannot be understood without accounting for the context, structure and metastructure derived from the unique combination and interactions between hierarchical elements and subsystems that make up the ecosystem. If we as stream ecologists



have largely ignored Hynes' (1975) idea of uniqueness, perhaps it is because we have lacked both the analytic tools to address the unique nature of each stream's hierarchical habitat discontinuum and the framework to integrate the concept of uniqueness into our thinking. Therefore, an especially important contribution of fluvial landscape ecology would be the development of tools and techniques that facilitate a discontinuum view of lotic ecosystems and address both the interactions between streams and their valleys and the unique nature of each lotic ecosystem's patch hierarchy. Fulfilling this need may allow Hynes' idea of uniqueness to become as deeply engrained into lotic system ecology as his ideas on river and valley interactions.

### Acknowledgments

Several years of discussions with Drs Jack Stanford and Chris Frissell provided me with many foundational ideas for this paper; conversations with Scott O'Daniel nurtured subsequent integration of those ideas with many others. Dr Frissell also provided invaluable comments on an early draft of this paper. Dr Leal Mertes, Cara Berman, Steve Ralph and one anonymous reviewer provided comments that improved the manuscript considerably. Dr George Malanson designed the sketch of a river discontinuum (Fig. 12b, right) on a napkin during a fruitful conversation.

### References

- Allan J.D. & Johnson L.B. (1997) Catchment-scale analysis of aquatic ecosystems. *Freshwater Biology*, **37**, 107–111.
- Allan J.D., Erickson D.L. & Fay J. (1997) The influence of catchment land use on stream integrity across multiple spatial scales. *Freshwater Biology*, **37**, 149–161.
- Allen T.F.H. & Starr T.B. (1982) *Hierarchy: Perspectives for Ecological Complexity*. University of Chicago Press, Chicago.
- Arcott D.B., Tockner K. & Ward J.V. (2000) Aquatic habitat structure and diversity along the corridor of an alpine floodplain river (the Fiume Tagliamento, Italy). *Archiv für Hydrobiologie*, **149**, 679–704.
- Band L.E., Patterson P., Nemani R. & Running S.W. (1993) Forest ecosystem processes at the watershed scale: incorporating hillslope hydrology. *Agriculture and Forest Meteorology*, **63**, 93–126.
- Band L.E., Tague C.L., Brun S.E., Tenenbaum D.E. & Fernandes R.A. (2000) Modelling watersheds as spatial object hierarchies: structure and dynamics. *Transactions in GIS*, **4**, 181–196.
- Baxter C.V. & Hauer F.R. (2000) Geomorphology, hyporheic exchange, and selection of spawning habitat by bull trout (*Salvelinus confluentus*). *Canadian Journal of Fisheries and Aquatic Sciences*, **57**, 1470–1481.
- Bisson P.A. & Montgomery D.R. (1996) Valley segments, stream reaches, and channel units. In: *Methods in Stream Ecology* (Eds F.R. Hauer & G.A. Lanberti), pp. 23–52. Academic Press, San Diego, CA.
- Bisson P.A., Quinn T.P., Reeves G.H. & Gregory S.V. (1992) Best management practices, cumulative effects, and long-term trends in fish abundance in Pacific Northwest river systems. In: *Watershed Management: Balancing Sustainability and Environmental Change* (Ed. R.J. Naiman), pp. 189–232. Springer-Verlag, New York.
- Cedarholm C.J., Reid L.M. & Salo E.O. (1981) Cumulative effects of logging road sediment on Salmonid populations in the clearwater river, Jefferson County, Washington. In: *Salmon Spawning Gravel: a Renewable Resource in the Pacific Northwest Proceedings*, pp. 38–74. State of Washington Water Research Center, Washington State University, Pullman.
- Chiarello E., Amoros C., Pautou G. & Jolion J.-M. (1998) Succession modelling of river floodplain landscapes. *Environmental Modelling and Software*, **13**, 75–85.
- Chorley R.J., Schumm S.A. & Sugden D.E. (1984) *Geomorphology*. Methuen, London.
- Church M. (1995) Geomorphic response to river flow regulation: case studies and time-scales. *Regulated Rivers: Research and Management*, **11**, 3–22.
- Church M. (2002) Geomorphic thresholds in riverine landscapes. *Freshwater Biology*, **47**, 541–557.
- Church M. & Mark D.M. (1980) On size and scale in geomorphology. *Progress in Physical Geography*, **4**, 342–390.
- D'Angelo D.J., Gregory S.V., Ashkenas L.R. & Meyer J.L. (1997) Physical and biological linkages within a stream geomorphic hierarchy: a modelling approach. *Journal of the North American Benthological Society*, **16**, 480–502.
- Dent C.L., Grimm N.B. & Fisher S.G. (2001) Multiscale effects of surface-subsurface exchange on stream water nutrient concentrations. *Journal of the North American Benthological Society*, **20**, 162–181.
- Fisher S.G. (1997) Creativity, idea generation and the functional morphology of streams. *Journal of the North American Benthological Society*, **16**, 305–318.
- Fisher S.G., Grimm N.B. & Gomez R. (1998) Hierarchy, spatial configuration and nutrient cycling in a desert stream. *Australian Journal of Ecology*, **23**, 41–52.

- Forman R.T.T. (1995) *Land Mosaics*. Cambridge University Press, Cambridge.
- Friend P.F. (1993) Control of river morphology by the grain-size of sediment supplied. *Sedimentary Geology*, **85**, 171–177.
- Frissell C.A., Liss W.J., Warren C.E. & Hurley M.D. (1986) A hierarchical framework for stream habitat classification: viewing streams in a watershed context. *Environmental Management*, **10**, 199–214.
- Gurnell A.M., Piégay H., Swanson F.J. & Gregory S.V. (2002) Large wood and fluvial processes. *Freshwater Biology*, **47**, 601–619.
- Heritage G.L., Charlton M.E. & O'Regan S. (2001) Morphological classification of fluvial environments: An investigation of the continuum of channel types. *Journal of Geology*, **109**, 21–33.
- Holling C.S. (1992) Cross-scale morphology, geometry, and dynamics of ecosystems. *Ecological Monographs*, **62**, 447–502.
- Hunsaker C.T. & Levine D.A. (1995) Hierarchical approaches to the study of water quality in rivers. *Bioscience*, **45**, 193–203.
- Hynes H.B.N. (1975) The stream and its valley. *Verhandlungen der Internationalen Vereinigung für Theoretische und Angewandte Limnologie*, **19**, 1–15.
- Johnson L.B. & Gage S.H. (1997) Landscape approaches to the analysis of aquatic ecosystems. *Freshwater Biology*, **37**, 113–132.
- Junk W.J., Bayley P.B. & Sparks R.E. (1989) The flood pulse concept in river-floodplain system. *Canadian Special Publication of Fisheries and Aquatic Sciences*, **106**, 110–127.
- Kay J.J. (2000) Ecosystems as self-organizing holarchic open systems: narratives and the second law of thermodynamics. In: *Handbook of Ecosystem Theories and Management* (Eds S.E. Jørgensen & F. Müller), pp. 135–160. Lewis Publishers, Boca Raton.
- Kotliar N.B. & Wiens J.A. (1990) Multiple scales of patchiness and patch structure: a hierarchical framework for the study of heterogeneity. *Oikos*, **59**, 253–260.
- Lane S. (1995) The dynamics of dynamic river channels. *Geography*, **80**, 147–162.
- Lane S.N. & Richards K.S. (1997) Linking river channel form and process: time, space and causality revisited. *Earth Surface Processes and Landforms*, **22**, 249–260.
- Levin S.A., Steele J.H. & Powell T.M. (1993) *Patch Dynamics*. Springer-Verlag, New York.
- MacKay D.S. & Band L.E. (1997) Forest ecosystem processes at the watershed scale: dynamic coupling of distributed hydrology and canopy growth. *Hydrological Processes*, **11**, 1197–1217.
- Malanson G.P. (1993) *Riparian Landscapes*. Cambridge University Press, New York.
- Malard F., Tockner K., Dole-Olivier M.-J. & Ward J.V. (2002) A landscape perspective of surface–subsurface hydrological exchanges in river corridors. *Freshwater Biology*, **47**, 621–640.
- Maridet L., Naiman R.J., Wasson J.-G., Philippe M. & Amoros C. (1998) Trophic structure of three streams with contrasting riparian vegetation and geomorphology. *Archiv für Hydrobiologie*, **144**, 61–85.
- Megahan W.F., Ptoyondy J.P. & Seyedbagheri K.A. (1992) Best management practices and cumulative effects from sedimentation in the South Fork Salmon River: an Idaho case study. In: *Watershed Management: Balancing Sustainability and Environmental Change* (Ed. R.J. Naiman), pp. 401–414. Springer-Verlag, New York.
- Montgomery D.R. (1999) Process domains and the river continuum. *Journal of the American Water Resources Association*, **35**, 397–410.
- Montgomery D.R., Beamer E.M., Pess G.R. & Quinn T.P. (1999) Channel type and salmonid spawning distribution and abundance. *Canadian Journal of Fisheries and Aquatic Sciences*, **56**, 377–387.
- Naiman R.J., Johnston C.A. & Kelley J.C. (1988) Alteration of North American streams by beaver. *Bioscience*, **38**, 753–762.
- Nemani R., Running S.W., Band L.E. & Peterson D. (1993) Regional hydro-ecological simulation system: an illustration of the integration of ecosystem models in a GIS. In: *Environmental Modeling with GIS* (Eds M.F. Goodchild, B.O. Parks & L.T. Steyaert), pp. 296–304. Oxford University Press, New York.
- Newson M.D. & Newson C.L. (2000) Geomorphology, ecology and river channel habitat: mesoscale approaches to basin-scale challenges. *Progress in Physical Geography*, **24**, 195–217.
- O'Neill R.V., DeAngelis D.L., Waide J.B. & Allen T.F.H. (1986) *A Hierarchical Concept of Ecosystems*. Princeton University Press, Princeton.
- Pattee H.H. (1973) *Hierarchy Theory*. Braziller, New York.
- Pickett S.T.A., Kolasa J., Armesto J. & Colins S.L. (1989) The ecological concept of disturbance and its expression at various hierarchical levels. *Oikos*, **54**, 129–136.
- Pinay G., Décamps H., Black V.J., Planty-Tabacchi A.M. & Gumiero B. (2000) Geomorphic control of denitrification in large river floodplain soils. *Biogeochemistry*, **50**, 163–182.
- Poff N.L. (1997) Landscape filters and species traits: towards mechanistic understanding and prediction in stream ecology. *Journal of the North American Benthological Society*, **16**, 391–409.
- Poole G.C. (2000) *Analysis and Dynamic Simulation of Morphologic Controls on Surface- and Ground-water Flux in a Large Alluvial Flood Plain*. PhD Dissertation.

- University of Montana, Missoula. (<http://www.eco-metrics.com>)
- Pringle C.M., Naiman R.J., Bretschko G., Karr J.R., Oswood M.W., Webster J.R., Welcomme R.L. & Winterbourn M.J. (1988) Patch dynamics in lotic systems: the stream as a mosaic. *Journal of the North American Benthological Society*, **7**, 503–524.
- Prosser I.P., Wallbrink P.J., Moran C.J., Rutherford I.D., Olley J.M. & Young W.J. (2001) Large-scale patterns of erosion and sediment transport in river networks, with examples from Australia. *Marine and Freshwater Research*, **52**, 81–99.
- Rice S.P., Greenwood M.T. & Joyce C.B. (2001) Tributaries, sediment sources, and the longitudinal organization of macroinvertebrate fauna along river systems. *Canadian Journal of Fisheries and Aquatic Sciences*, **58**, 824–840.
- Rot B.W., Naiman R.J. & Bilby R.E. (2000) Stream channel configuration, landform, and riparian forest structure in the Cascade Mountains, Washington. *Canadian Journal of Fisheries and Aquatic Sciences*, **57**, 699–707.
- Roth N.E., Allen J.D. & Erickson D.L. (1996) Landscape influences on stream biotic integrity assessed at multiple spatial scales. *Landscape Ecology*, **11**, 141–156.
- Schumm S.A. (1977) *The Fluvial System*. John Wiley, New York.
- Sedell J.R. & Froggatt J.L. (1984) Importance of streamside forests to large rivers: the isolation of the Willamette River, Oregon, U.S.A., from its floodplain by snagging and streamside forest removal. *Verhandlungen der Internationalen Vereinigung für Theoretische und Angewandte Limnologie*, **22**, 1828–1834.
- Sedell J.R., Richey J.E. & Swanson F.J. (1989) The river continuum concept: a basis for the expected ecosystem behavior of very large rivers? *Canadian Special Publication of Fisheries and Aquatic Sciences*, **106**, 49–55.
- Stanford J.A., Hauer F.R. & Ward J.V. (1988) Serial discontinuity in a large river system. *Verhandlungen der Internationalen Vereinigung für Theoretische und Angewandte Limnologie*, **23**, 1114–1118.
- Stanford J.A. & Ward J.V. (1993) An ecosystem perspective of alluvial rivers: connectivity and the hyporheic corridor. *Journal of the North American Benthological Society*, **12**, 48–60.
- Tabacchi E., Correll D.L., Hauer R., Pinay G., Planty-Tabacchi A.-M. & Wissmar R.C. (1998) Development, maintenance, and role of riparian vegetation in the river landscape. *Freshwater Biology*, **40**, 497–516.
- Tockner K., Malard F. & Ward J.V. (2000) An extension of the flood pulse concept. *Hydrological Processes*, **14**, 2861–2883.
- Townsend C.R. (1989) The patch dynamics concept of stream community ecology. *Journal of the North American Benthological Society*, **8**, 36–50.
- Townsend C.R. (1996) Concepts in river ecology: pattern and process in the catchment hierarchy. *Archiv für Hydrobiologie*, **113 (Suppl.)**, 3–21.
- Triska F.J. (1984) Role of wood debris in modifying channel geomorphology and riparian areas of a large lowland river under pristine conditions: a historical case study. *Verhandlungen der Internationalen Vereinigung für Theoretische und Angewandte Limnologie*, **22**, 1876–1892.
- Turner M.G. (1989) Landscape ecology: the effect of pattern on process. *Annual Review of Ecology and Systematics*, **20**, 171–197.
- Urban D.L., O'Neill R.V. & Shugart H.H. (1987) Landscape ecology: a hierarchical perspective can help scientists understand spatial patterns. *Bioscience*, **37**, 119–127.
- Vannote R.L., Minshall G.W., Cummins K.W., Sedell J.R. & Cushing C.E. (1980) The river continuum concept. *Canadian Journal of Fisheries and Aquatic Science*, **37**, 130–137.
- Walsh S.J., Butler D.R. & Malanson G.P. (1998) An overview of scale, pattern, process relationships in geomorphology: a remote sensing and perspective. *Geomorphology*, **21**, 183–205.
- Ward J.V. (1989) The four-dimensional nature of lotic ecosystems. *Journal of the North American Benthological Society*, **8**, 2–8.
- Ward J.V. (1997) An expansive perspective of riverine landscapes: pattern and process across scales. *GAIA*, **6**, 52–60.
- Ward J.V. (1998) Riverine landscapes: biodiversity patterns, disturbance regimes, and aquatic conservation. *Biological Conservation*, **83**, 269–278.
- Ward J.V. & Stanford J.A. (1983) Serial discontinuity concept of lotic ecosystems. In: *Dynamics of Lotic Systems* (Eds T.D. Fontaine & S.M. Bartell), pp. 29–42. Ann Arbor Science, Ann Arbor.
- Ward J.V. & Stanford J.A. (1995) The serial discontinuity concept: extending the model to floodplain rivers. *Regulated Rivers: Research and Management*, **10**, 159–168.
- Ward J.V. & Tockner K. (2001) Biodiversity: towards a unifying theme for river ecology. *Freshwater Biology*, **46**, 807–819.
- Ward J.V., Bretschko G., Brunke M., Danielopol D., Gibert J., Gonser T. & Hildrew A.G. (1998) The boundaries of river systems: the metazoan perspective. *Freshwater Biology*, **40**, 531–569.
- Wiens J.A. (2002) Riverine landscapes: taking landscape ecology into the water. *Freshwater Biology*, **47**, 501–515.

Wu J. & Loucks O.L. (1995) From balance of nature to hierarchical patch dynamics: a paradigm shift in ecology. *Quarterly Review of Biology*, **70**, 439–466.

(Manuscript accepted 4 November 2001)

## Appendix

A simple, hierarchical model of *Hynsite* and *Forsite* solute dynamics divides the mainstem of a river into segments 5 km in length. The distribution of segments along the downstream profile (metastructure of segments) determines the downstream pattern of *Hynsite* equilibrium concentration and lateral and vertical exchange (Fig. 12).

The model calculates change in *Hynsite* concentration using a constant transformation rate multiplied by the difference between channel *Hynsite* concentration and equilibrium concentration for the segment. Thus, the change in *Hynsite* concentration is the greatest where the channel concentration is farthest from equilibrium. Once the change in *Hynsite* concentration is applied to the *Hynsite* discharged from upstream, the *Hynsite* in a stream segment is calculated as the flow-weighted average of lateral *Hynsite* inputs and upstream discharge:

$$S_x = [(S_{(x-1)} - S_{eqx}) \cdot kS_{(x-1)} \cdot Q_{(x-1)} + S_b \cdot Q_b] / Q_x \quad (1)$$

where  $S_x$  is the solute concentration in segment  $x$ ,  $S_{(x-1)}$  is the solute concentration in the segment upstream of segment  $x$ ,  $S_{eqx}$  is the equilibrium solute concentration for segment  $x$ ,  $k$  is the solute transformation rate coefficient,  $Q_{(x-1)}$  is the river discharge in the upstream segment,  $S_b$  is the solute concentration delivered to each segment from the drainage basin,  $Q_b$  is the hillslope water flow rate into each segment from the drainage basin,  $Q_x$  is the discharge in segment  $x$  (calculated as  $Q_{(x-1)} + Q_b$ ). *Forsite* concentrations are

simulated using two equations. The first equation is identical to Eqn (1), except  $S'_{(x-1)}$  is substituted for  $S_{(x-1)}$  and the equilibrium concentration for *Forsite* ( $S_{eq}$ ) is assumed to be a constant, low value (0.01) along the stream course, thus eliminating longitudinal connectivity as an influence on *Forsite* concentrations.

The second equation calculates  $S'_x$  by using the fraction of channel flow that is exchanged laterally/vertically between the channel and floodplain (Fig. 12) to find the weighted average of  $S_x$  [from Eqn (1)] and the *Forsite* concentration associated with the flood-plain water and ground water (a constant, high value of 1.0):

$$S'_x = F \cdot L_x + S_x(1 - L_x) \quad (2)$$

where  $S'_x$  is the final solute concentration (incorporating lateral and vertical exchange) for segment  $x$ ,  $F$  is the solute concentration associated with floodplain,  $L_x$  is the fraction instream flow exchanged laterally and vertically with floodplain in segment  $x$ ,  $S_x$  is the interim solute concentration (instream transformation plus inputs from the drainage basin) in segment  $x$ ,

In simulations of *Hynsite* and *Forsite* that consider network branching structure, Eqn (1) is modified at tributary confluences to add tributary water and solutes to the main channel:

$$S_x = [(S_{(x-1)} - S_{eqx}) \cdot k \cdot S_{(x-1)} \cdot Q_{(x-1)} + S_b \cdot Q_b + S_y \cdot Q_y] / Q_x \quad (3)$$

where  $S_y$  is the solute concentration at the mouth of the tributary,  $Q_y$  is the discharge at the mouth of the tributary,  $Q_x$  is the discharge in segment  $x$  calculated as  $Q_{(x-1)} + Q_b + Q_y$ . Solute concentrations at the mouth of each tributary were determined by simulating solute dynamics along each tributary using Eqns (1) and (2).